

CATALOG NO.	ACCOMMODATES CONDUCTOR RANGE			REFERENCE DIMENSIONS			RECOMMENDED SCREW TORQUE " INCH POUNDS "	
	WATER PIPE	REBAR	GROUND	H	L	W	PIPE CLAMP	WIRE CLAMP
4 C-5 (JUNIOR)	1/2-1 [13-25]	- - -	10-2 STR	1.56 [40]	2.25 [56]	.56 [14]	50 LB-IN.	50 LB-IN.
C-11N		#4-#8		1.81 [46]		.63 [16]		
C-11D			1 1/4-2 [32-51]	10-2 STR	2.38 [60]	3.63 [92]		
C-11B								
C-22								
C-22D	2 1/2-4 [64-114]	10-2 STR	4.13 [105]	6.25 [159]	.96 [24]			
C-22B								
C-4	4 1/2-6 [114-165]	10-2 STR	4.29 [109]	8.34 [212]	1.25 [32]			
C-8								

REV.	DATE	DESCRIPTION	ECO	BY	C'H'K.
B	12/11/2008 8:49:00 AM	ADD NOTE 9 TO DRAWING PER M/U.	17166	RLB	JP

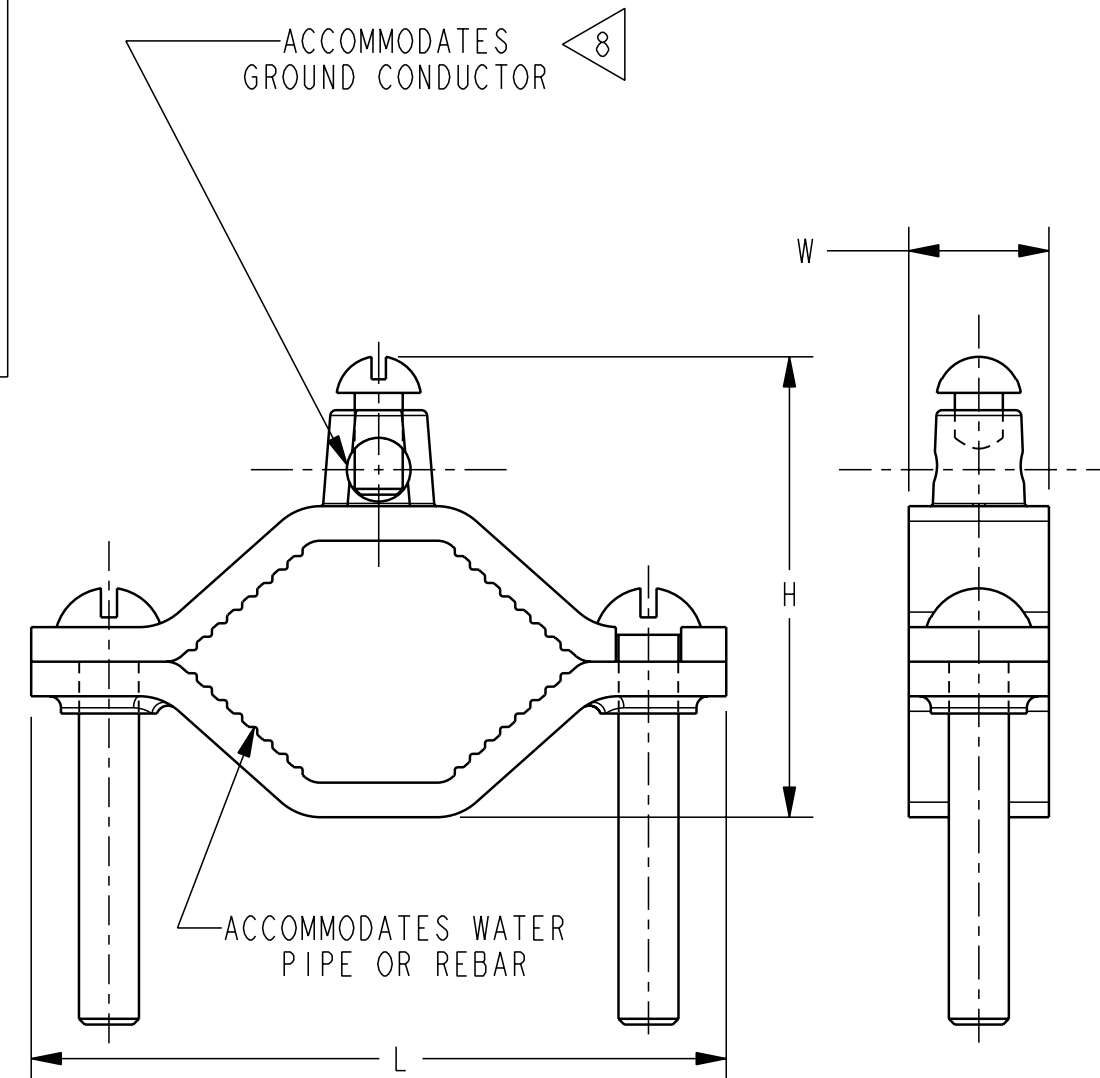

NOTES:

- MATERIAL:
BODY: SOLID CAST BRONZE.
HARDWARE: STEEL, ZINC PLATED. (ACCEPT AS NOTED)
- CONNECTORS ARE UL LISTED TO STANDARD UL467, GROUNDING AND BONDING EQUIPMENT. FOR INDICATED CONDUCTOR RANGE.
- CONNECTORS ARE CSA CERTIFIED TO STANDARD C22.2, NO. 41, GROUNDING AND BONDING EQUIPMENT FOR INDICATED CONDUCTOR RANGE.
- 4 LOW COST, ECONOMY CONNECTOR.
- CATALOG NUMBERS WITH SUFFIX "D" INDICATED THAT CONNECTORS ARE UL467 LISTED FOR DIRECT BURIAL IN EARTH AND CONCRETE, AND ARE SUPPLIED WITH SILICON BRONZE HARDWARE. (EXAMPLE: C-11D)
- CATALOG NUMBERS WITH SUFFIX "B" INDICATED THAT CONNECTORS ARE SUPPLIED WITH BRASS HARDWARE. (EXAMPLE: C-11B)
- DIMENSIONS IN BRACKETS [] ARE IN MILLIMETERS ROUNDED TO THE NEAREST WHOLE NUMBER. UNLESS OTHERWISE NOTED, AND ARE FOR REFERENCE ONLY.
- 8 CONDUCTOR HOLE DIA. IS .31 [8].
- TO ACCOMMODATE THE SMALLER WATER PIPE SIZES, SOME CONNECTORS REQUIRE THE INSTALLER TO REVERSE THE BOTTOM SADDLE PORTION OF THE PIPE CLAMPING ELEMENT.

TO ORDER BURNDY® PRODUCTS CALL		GRD. CLAMPS, RIGID CONDUIT W/STRAP-WATER PIPE	
UNITED STATES:		ITEM NO: 10001488	
1-800-346-4175 (LONDONDERRY, NH)		CAT. NO: C- (SEE TABLE)	
CANADA:		DRAWN BY: D. DOBRINSKI 01/10/97	
1-800-361-6975 (QUEBEC)		CHECKER: D.D. 04/17/97	
1-800-387-6487 (ALL OTHER PROVINCES)		DSN APPVL: K. MELLO 04/18/97	
FOR PRODUCT INFO: http://www.fciconnect.com		MFG APPVL: --	
		QA APPVL: D. VARIO 04/23/97	
		MKT APPVL: P. WERTHMAN 04/23/97	
		SCALE: 1:1	
		DRAWING NO	
		PROJECT #: --	
		SIZE	
		DOCUMENT TYPE: --	
		REL LEVEL: Released	
		DRAWING NO	
		REV	
		SC210654-01	
		B	
		SHEET 1 OF 1	

REV: PE0200